

# Headwall

**Drainage Outfalls and Inlets**



 **ALTHON HEADWALL**

Issue 5 - July 2009

## Index

Overview	Page 2
Precast Concrete Headwalls	Page 3-7
Precast Concrete Headwall Specials	Page 8-9
Precast Concrete Headwalls continued	Page 10
Headwall Gratings and Ground Anchors	Page 11
Precast Concrete Culvert Wingwalls	Page 12
Glass Reinforced Cement Headwalls	Page 13
Precast Concrete Silt Traps	Page 14
Installation Instructions	Page 15

Althon Headwalls offer a cost effective alternative to in-situ structures for connecting pipework discharging into open watercourses. All drainage pipes discharging into open watercourses, such as Swales, Ditches, Ponds and Rivers, should be fitted with a suitable headwall. These units help to protect and locate outfall pipes and to minimise erosion at the point of discharge. Althon Headwalls can accommodate pipework with an internal diameter of up to and including 1650mm ID and PCC Box Culverts up to 2400mm wide x 1500mm deep. Multiple pipe outlets can also be accommodated.

**Structural Analysis in accordance with BS EN 1992-1-1:2004 Eurocode 2: Design of Concrete Structures is available for the H3C, H6C, H10C, H20C, H28C, CH20C and CH28C range of headwalls, please contact the Althon Sales office for details.**

Headwall units can be fitted with or supplied with a range of accessories such as Flap Valves, Penstocks, Grates, Hand Railing etc. See pages 8 and 9 for details.



Wherever water is to be fed from an open watercourse into a pipe outlet, an Althon Silt Trap Inlet should be provided. The sloped grating minimises the risk of blockage from floating material, and silt will be collected by the Silt Chamber prior to the outfall pipe. Althon manufacture a range of Silt Trap Inlets to cater for pipework with an internal diameter of up to and including 1200mm.

Althon Headwalls and Silt Traps have been used on contracts requiring approval from organisations such as the Environment Agency, Local Authorities and the Highways Agency. Althon Headwalls and Silt Traps are quick and simple to install and reduce the need for skilled labour.

## Precast Concrete Headwalls

Please note when reviewing this information openings shown on illustrations for pipe entry are indicative only. See tables for maximum opening sizes.

If a Penstock or Flap Valve is to be fitted to the Headwall, the frame size will determine the maximum pipe diameter that can be accommodated – please contact the Althon Sales Office for details.

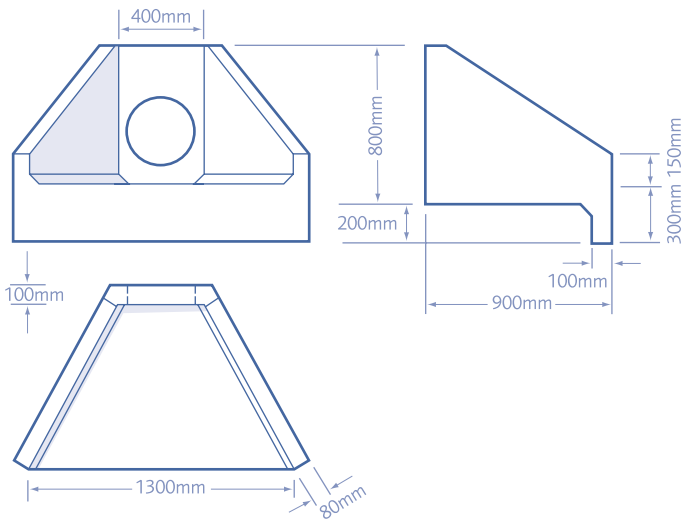

### Althon Headwall H3C

Approximate weight 540kg.

A one-piece reinforced concrete headwall to suit Plastic or Clayware pipes up to 300mm I.D. or PCC pipes up to 225mm I.D. Stainless steel sockets are provided for the attachment of gratings. Lifting points are cast in to each Wingwall for safe handling using Althon Lifting Clutches.

A Toe extension piece is available for the H3C Headwall giving an overall Toe depth of 810mm from the splashplate, see the Althon website for details.

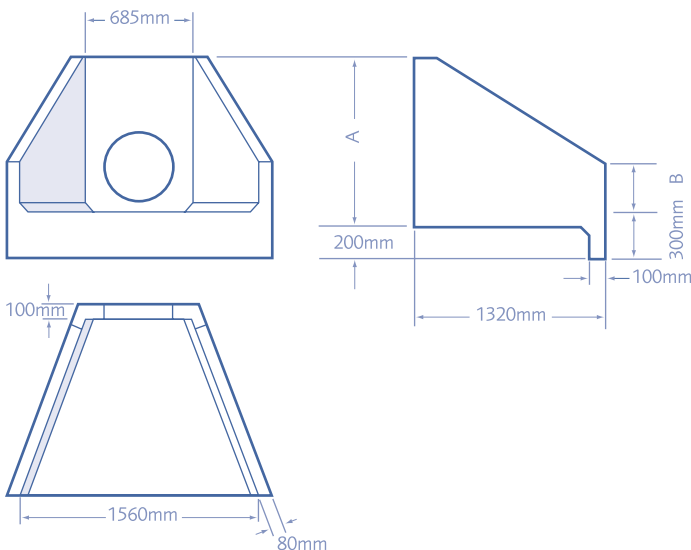

### Althon Headwall H6C

A one-piece reinforced concrete headwall to suit Plastic or Clayware pipes up to 500mm I.D. or PCC pipes up to 450mm I.D. Available with three standard backwall heights, 1.1m, 1.5m and 2m, with Lifting points cast in to each Wingwall for safe handling using Althon Lifting Clutches.

Stainless steel sockets are provided for the attachment of Gratings and special brackets are available for use with the anchorage system. See Page 11 for details.

Toe extension pieces are available for the H6C Headwall giving an overall Toe depth of 710mm or 1015mm from the splashplate, see the Althon website for details.

Headwall	Max Pipe Opening (I.D.) Plastic/C'ware	Max Pipe Opening PCC	A	B	Approx Weight kg
H6C A	500	450	1100	320	940
H6C B	500	450	1550	410	1150
H6C C	500	450	2050	410	1375

# HEADWALL

www.althon.co.uk  
01603 488700

## Althon Headwall H10C

A one-piece reinforced concrete headwall to suit Plastic, Clayware or PCC pipes up to 900mm I.D. Available with three standard backwall heights, 1.25m, 1.65m and 2.1m, with Lifting points cast in to each Wingwall for safe handling using Althon Lifting Clutches. A spreader bar is also recommended for safe Handling.

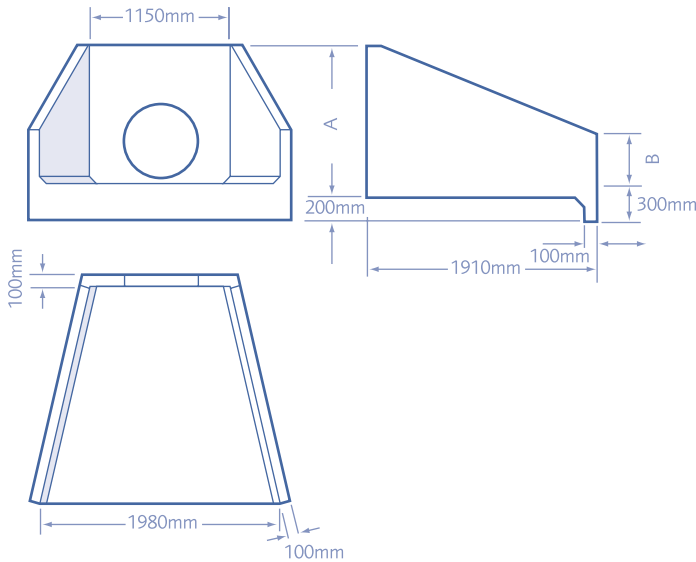

The chains are threaded through this eliminating side load on the vertical lift. Stainless steel sockets are provided for the attachment of Gratings and special brackets are available for use with the anchorage system. See Page 11 for details.

Toe extension pieces are available for the H10C Headwall giving an overall Toe depth of 710mm or 1015mm from the splashplate, see the Althon website for details.

Headwall	Max Pipe Opening (I.D.) Plastic/C'ware	Max Pipe Opening PCC	A	B	Approx Weight kg
H10C A	900	750	1250	300	2000
H10C B	900	900	1650	700	2300
H10C C	900	900	2130	200	2500
H10C D	900	750	1250	1150	2300
H10C E	900	900	1650	1550	2600
H10C F	900	900	2130	2030	2800

## Althon Angled Headwalls

A one-piece reinforced concrete headwall to suit Plastic, Clayware or PCC Pipes up to 900mm I.D. Available with three standard backwall heights, 1.25m, 1.65m and 2.1m, with Lifting points cast in to each Wingwall for safe handling using Althon Lifting Clutches. A spreader bar is also recommended for safe handling. The chains are threaded through this eliminating side load on the vertical lift. Stainless steel sockets are provided for the attachment of Gratings and special brackets are available for use with the anchorage system. See Page 11 for details. These headwalls allow pipework entering a

watercourse at an angle to be accommodated or for an Outfall to be sited on a bend in a river. The toe is cast separately and is available in depths of 305, 610, 915, 1220 or 1420mm dependant on site conditions. The toe is fixed to the underside of the Headwall with 5 Stainless Steel Bolts which are fastened from the top and are hidden in a recess cast into the splashplate.

Right Hand Angled Headwall

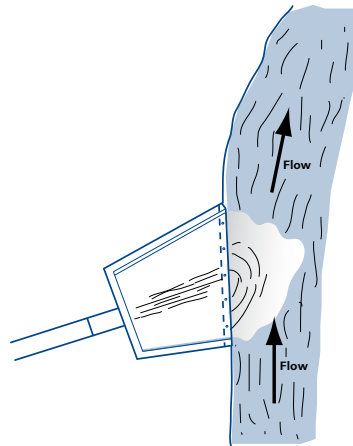

Left Hand Angled Headwall

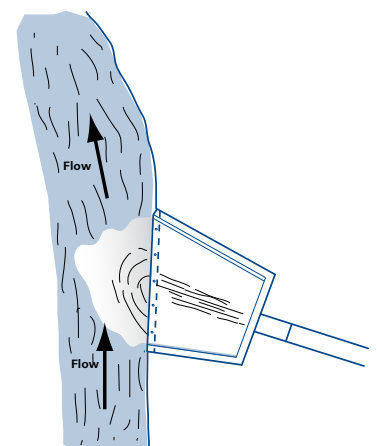

## Althon Angled Headwall AH10C RH

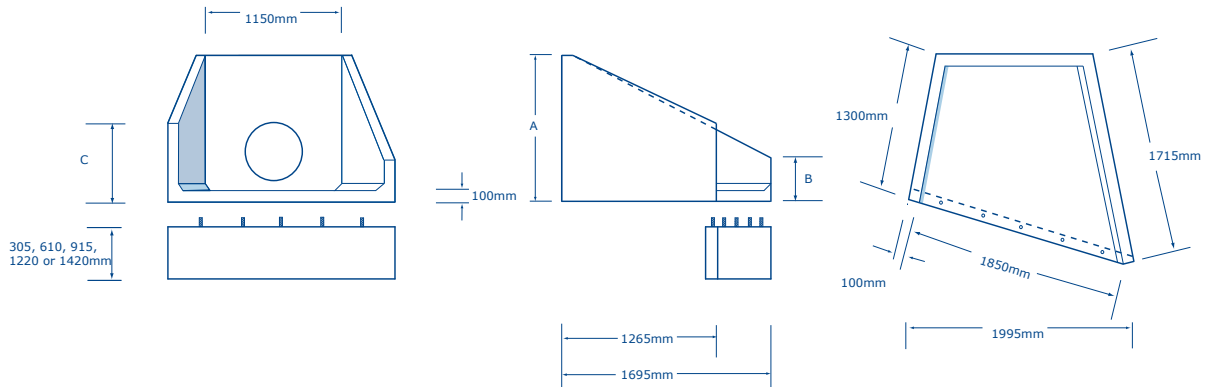

Headwall	Max Pipe Opening (I.D.) Plastic/C'Ware	Max Pipe Opening (I.D.) PCC	A	B	C	Approx Weight kg
AH10C RH A	900	750	1250	400	595	2000
AH10C RH B	900	900	1650	800	995	2300
AH10C RH C	900	900	2130	415	830	2500

## Althon Angled Headwall AH10C LH

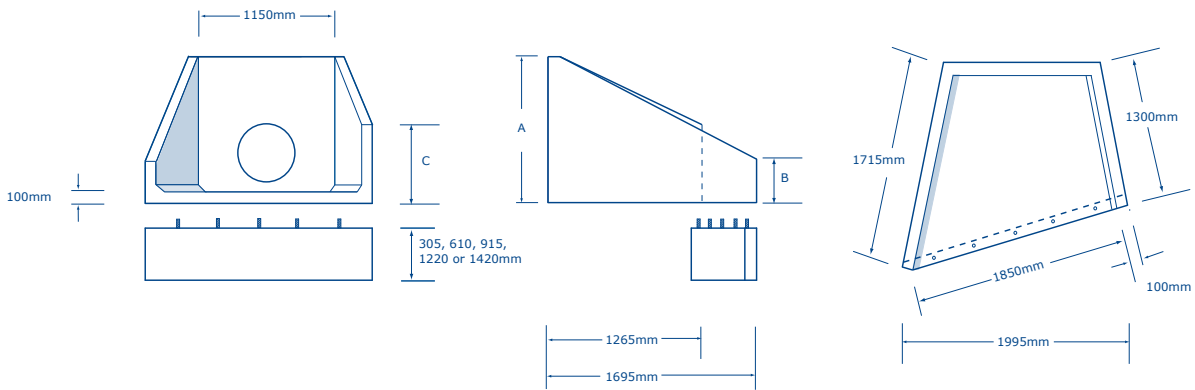

Headwall	Max Pipe Opening (I.D.) Plastic/C'Ware	Max Pipe Opening (I.D.) PCC	A	B	C	Approx Weight kg
AH10C LH A	900	750	1250	350	565	2000
AH10C LH B	900	900	1650	370	770	2300
AH10C LH C	900	900	2130	770	995	2500

**HEADWALL**

www.althon.co.uk  
01603 488700

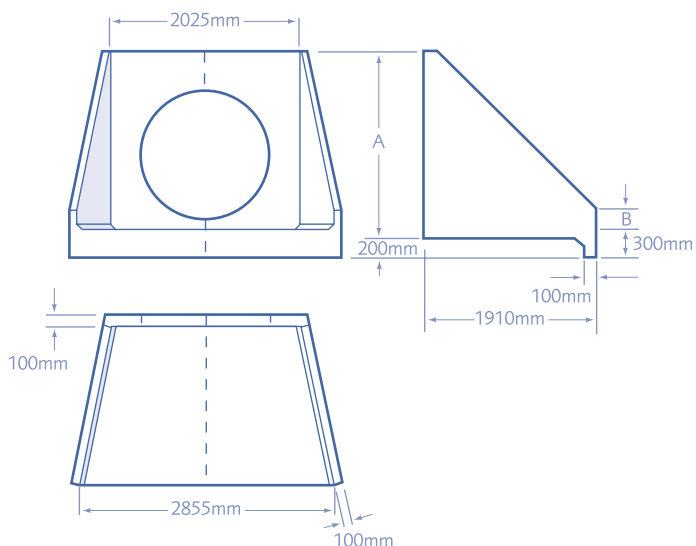

Stainless steel sockets are provided for the attachment of Gratings and special brackets are available for use with the anchorage system. See Page 11 for details.

## Althon Headwall H20C

This is a sectional structure with rebated joint, assembled on site around the drainage pipe and locked together by means of stainless steel cast-in sockets and brackets provided. The H20C Headwall is suitable for plastic or clayware pipes up to 1650mm I.D. or PCC pipes up to 1500mm I.D. Available with three standard backwall heights, 1.25m, 1.65m and 2.1m, with Lifting points cast in to each Wingwall for safe handling using Althon Lifting Clutches.

Headwall	Max Pipe Opening (I.D.) Plastic/C/ware	Max Pipe Opening (I.D.) PCC	A mm	B mm	Approx Weight kg
H20C A	900	900	1250	300	2600
H20C B	1050	1050	1650	700	3200
H20C C	1650	1500	2130	200	3600
H20C D	900	900	1250	1150	3000
H20C E	1050	1050	1650	1550	3600
H20C F	1650	1500	2130	2030	4000

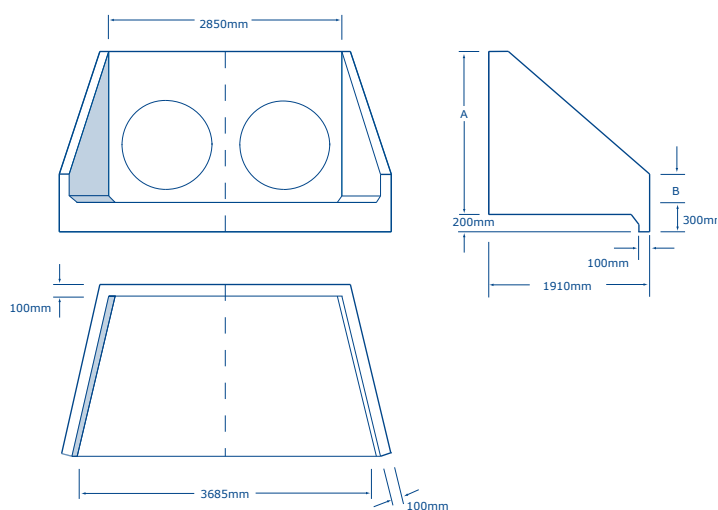

## Althon Headwall H28C

This is a sectional structure with rebated joint, assembled on site around the drainage pipe and locked together by means of stainless steel cast-in sockets and brackets provided. The H28C Headwall is suitable for plastic pipes up to and including 1650mm ID or PCC Pipes up to and including 1500mm ID. This headwall will also accommodate Twin pipe openings of up to and including 1050mm ID plastic and 900mm ID PCC. Available with three standard backwall heights, 1.25m, 1.65m and 2.1m, with Lifting points cast in to each Wingwall for safe handling using Althon Lifting Clutches. Stainless steel sockets are provided for the attachment of Gratings and special brackets are available for use with the anchorage system. See Page 11 for details.

Headwall	Max Pipe Opening (I.D.) Plastic	Max Pipe Opening (I.D.) Concrete	A	B	Approx Weight kg
H28C A	900/Twin 900	750/Twin 750	1250	300	3400
H28C B	1200/Twin 1050	1050/Twin 900	1650	700	4100
H28C C	1650/Twin 1050	1500/Twin 900	2130	200	4400



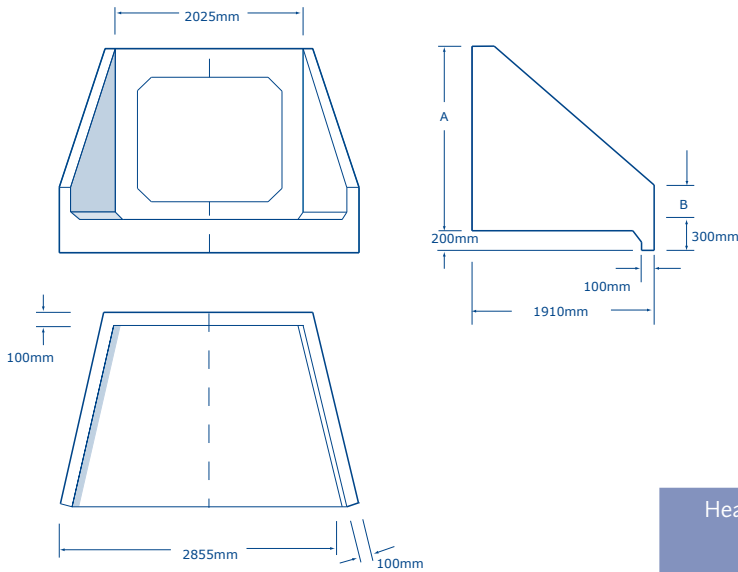

## Althon Culvert Headwall CH20C

This is a sectional structure with rebated joint, assembled on site around the box culvert and locked together by means of stainless steel cast-in sockets and brackets provided. The Althon Culvert Headwall CH20C will accommodate box culverts with a maximum internal dimension of 1500mm wide x 1500mm high. Available with three standard backwall heights, 1.25m, 1.65m and 2.1m, with Lifting points cast in to each Wingwall for safe handling using Althon Lifting Clutches. Stainless steel sockets are provided for the attachment of Gratings and special brackets are available for use with the anchorage system. See Page 11 for details.

Headwall	Max Internal Dimensions PCC Box Culvert	A	B	Approx Weight kg
CH20C A	1500 x 800	1250	300	2600
CH20C B	1500 x 1200	1650	700	3200
CH20C C	1500 x 1500	2130	200	3600
CH20C D	1500 x 800	1250	1150	3000
CH20C E	1500 x 1200	1650	1550	3600
CH20C F	1500 x 1500	2130	2030	4000

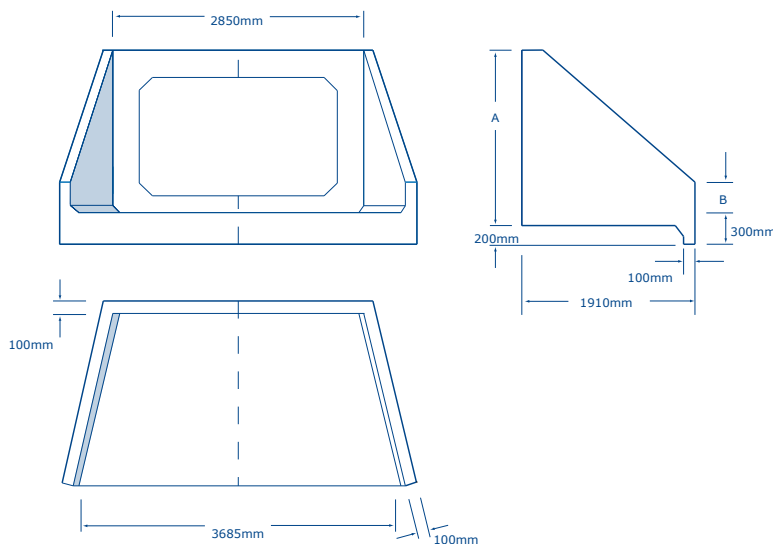

## Althon Culvert Headwall CH28C

This is a sectional structure with rebated joint, assembled on site around the box culvert and locked together by means of stainless steel cast-in sockets and brackets provided. The Althon Culvert Headwall CH28C will accommodate culverts with a maximum internal dimension of 2400mm wide x 1500mm high. Available with three standard backwall heights, 1.25m, 1.65m and 2.1m, with Lifting points cast in to each Wingwall for safe handling using Althon Lifting Clutches. Stainless steel sockets are provided for the attachment of Gratings and special brackets are available for use with the anchorage system. See Page 11 for details.

Headwall	Max Internal Dimensions PCC Box Culvert	A	B	Approx Weight kg
CH28C A	2400 x 800	1250	300	3400
CH28C B	2400 x 1200	1650	700	4100
CH28C C	2400 x 1500	2130	200	4400

# HEADWALL

[www.althon.co.uk](http://www.althon.co.uk)  
01603 488700

Customer requests for alterations and additions to our standard designs of drainage outlet over the years have allowed us to gain considerable experience in providing exactly what the client requires.

EXTENDED SPILLWAYS

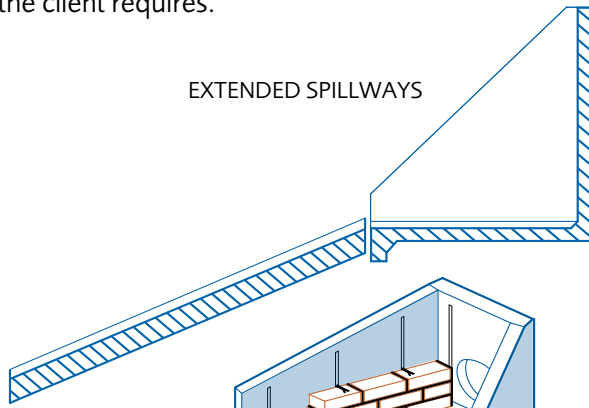

EXTRA WEIR WALLS  
CAST IN ("V" NOTCH)

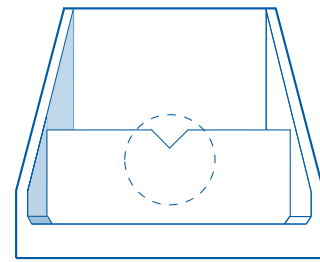

DOVETAIL SLOTS CAST  
IN TO ALLOW CLADDING OF  
WINGWALLS AND BACKWALL

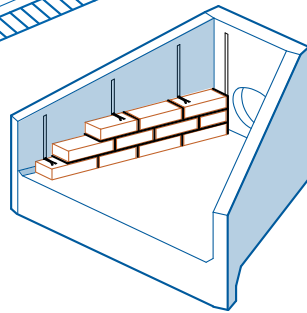

ORIFICE PLATES  
(FLOW CONTROL)

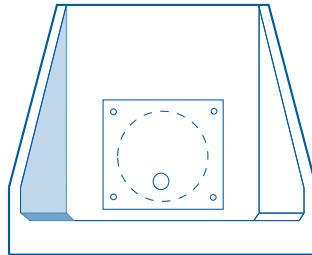

MULTIPLE PIPE OPENINGS

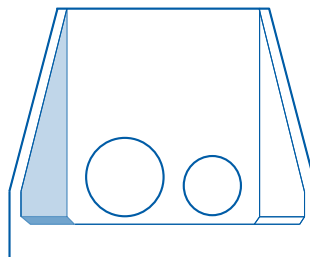

EXTENDED TOES

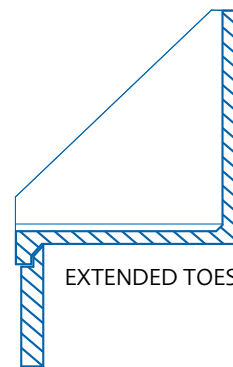

HEADWALL ADAPTED  
FOR USE AS SILT TRAP

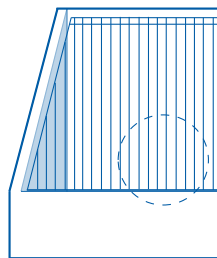

This page gives an overview of the alterations and additions that can be accommodated. For more specific information, please visit our website [www.althon.co.uk](http://www.althon.co.uk) If you can't see what you are looking for please contact our sales office on 01603 488700

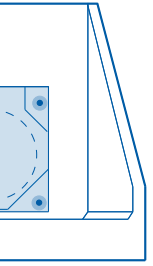

FLAP VALVES

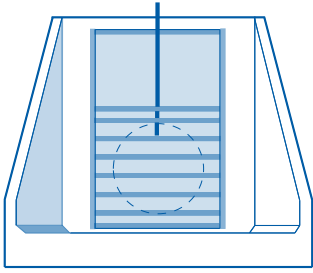

PENSTOCKS

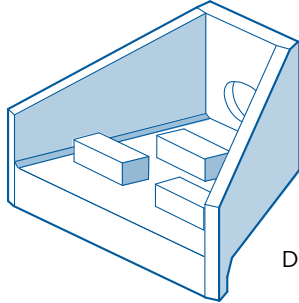

DIFFUSER BLOCKS

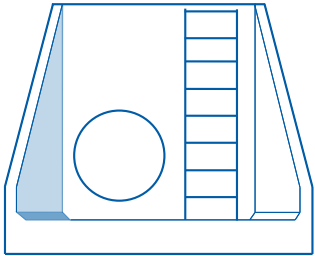

ACCESS LADDERS OR RUNG IRONS CAST IN

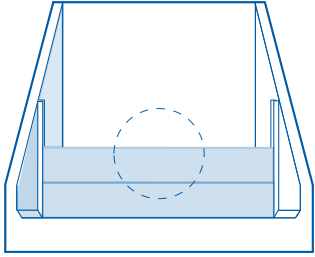

STOP LOGS

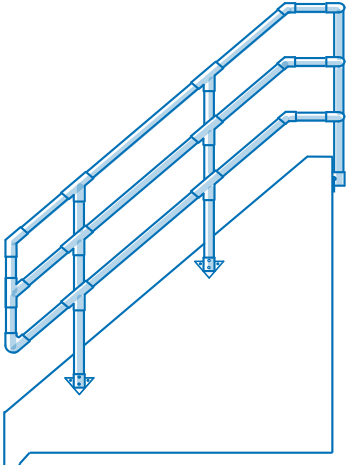
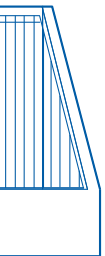

HANDRAILING

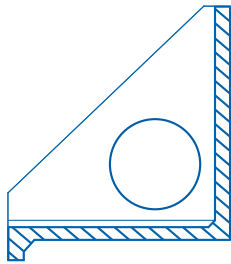

PIPE OPENING IN WINGWALLS

# HEADWALL

[www.althon.co.uk](http://www.althon.co.uk)  
01603 488700

## Althon Headwall H40 Series

A one-piece reinforced concrete headwall available in three widths and five standard heights. Particularly suitable for steep embankments. Due to the relatively narrow footprint of the unit (back to front) it is advisable to fit suitable brackets to attach ground anchors (see Page 11). The largest unit can accommodate PCC Pipes up to 1050mm I.D. and Plastic Pipes up to 1200mm I.D. Stainless steel sockets are provided for the attachment of Gratings. Lifting points are cast in to each Wingwall for safe handling using Althon Lifting Clutches. Galvanised Mild Steel Angle can be fitted to the side walls in order to fit Stoplogs and the back wall can be extended horizontally through the fitting of side wall extensions if required.

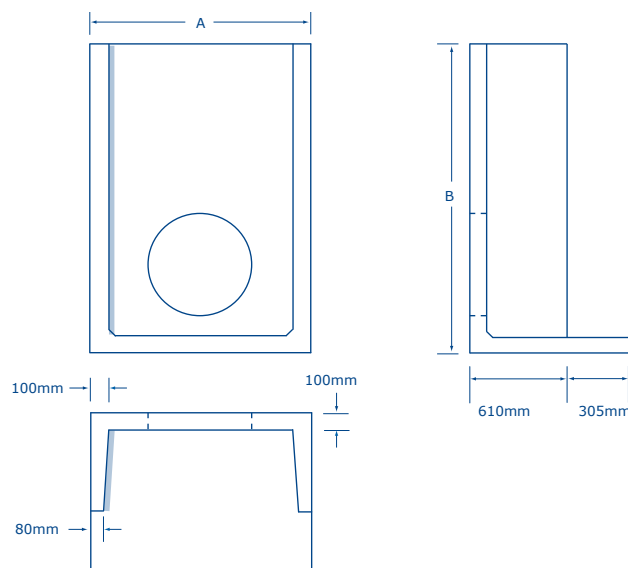

Headwall	Max Pipe Opening (I.D.) Plastic/C'Ware	Max Pipe Opening (I.D.) PPC	A	B	Approx Weight kg
H40C A	600	525	1070	1120	700
H40C B	600	525	1070	1425	850
H40C C	600	525	1070	1730	980
H40C D	600	525	1070	2035	1120
H40C E	600	525	1070	2340	1280

Headwall	Max Pipe Opening (I.D.) Plastic/C'Ware	Max Pipe Opening (I.D.) PPC	A	B	Approx Weight kg
H42C A	600	600	1375	1120	810
H42C B	750	750	1375	1425	1070
H42C C	750	750	1375	1730	1230
H42C D	750	750	1375	2035	1390
H42C E	750	750	1375	2340	1550

Headwall	Max Pipe Opening (I.D.) Plastic/C'Ware	Max Pipe Opening (I.D.) PPC	A	B	Approx Weight kg
H44C A	600	600	1680	1120	990
H44C B	750	750	1680	1425	1170
H44C C	1200	1050	1680	1730	1380
H44C D	1200	1050	1680	2035	1540
H44C E	1200	1050	1680	2340	1730

Please note that the units shown are standard units but we may be able to offer variations on request



[sales@althon.co.uk](mailto:sales@althon.co.uk)

## Grating Configurations for Althon Headwalls

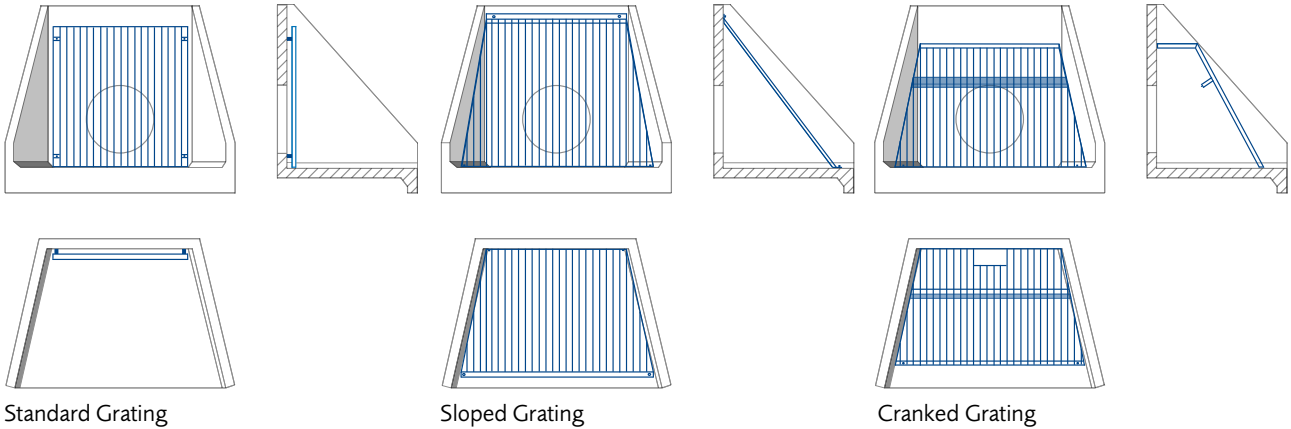

Althon Headwalls can be supplied fitted with either Mild Steel (unit fully welded then hot dip galvanised) or stainless steel gratings. Three different configurations are available. Gratings provide safety against persons entering the pipe or culvert and protection against the ingress of debris.

The Sloped Grating is normally used where a Flap Valve is fitted; it allows the Flap Valve to operate efficiently and offers better protection against blockage as it allows debris to be pushed up the grating as the water level rises, minimising build up and potential blockage.

The Cranked Grating is normally used where a large Flap Valve or Penstock is fitted. This type of grating allows the Flap Valve or Penstock to operate efficiently. Special access points can be made available within the grating to allow access to operating gear for Penstocks etc.

Bespoke gratings can be manufactured to suit customer requirements, please contact the Althon Sales Office for further details.

## Althon Headwall Ground Anchors

It may be felt necessary on some of the taller headwall units that an anchor system is required. Althon can provide a Galvanised Mild Steel Anchor system manufactured from 50 x 50mm Angle Iron. The anchors are driven into the ground either side of the pipe and are connected to the rear of the headwall with stainless steel studding which can be up to 3000mm long. Backfilling is then performed as normal.

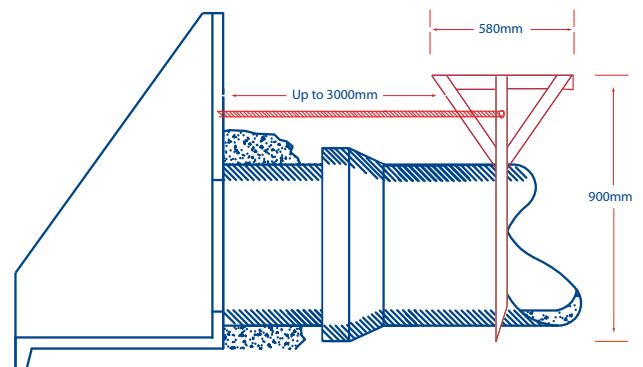

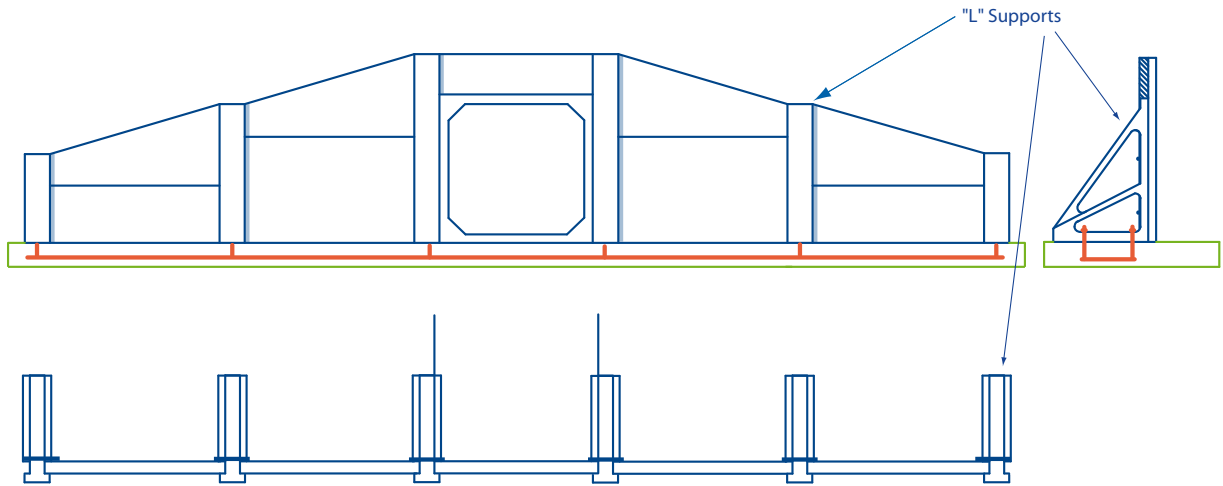

## Althon Culvert Wingwalls

Althon are able to offer a purpose made PCC Culvert Wingwall system. The system comprises of "L" shaped supports that are located on a lattice framework which is set into the concrete base cast on site. Front and side walls up to 150mm thick are secured to the supports by means of angle brackets which are at the rear of the structure and not seen from the front. The front walls can be cast to accommodate single or multiple pipe openings, box culverts and corrugated steel culverts. The Wingwalls can be set at any angle in relation to the Culvert end, and up to a maximum height of 4m. Safety or Debris Gratings to suit the Culvert opening can be supplied as well as other accessories such as Flap Valves, Penstocks, and Handrails etc.

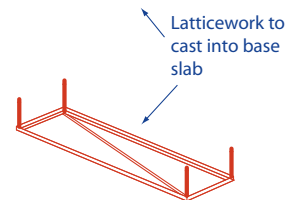
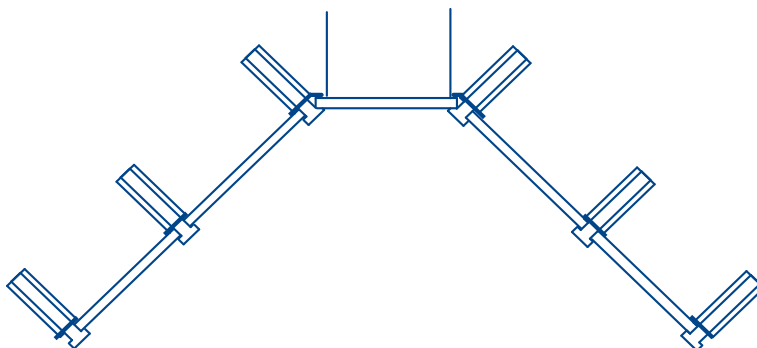
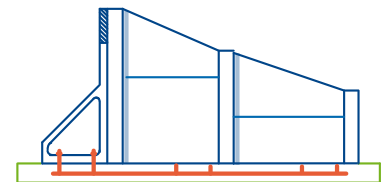
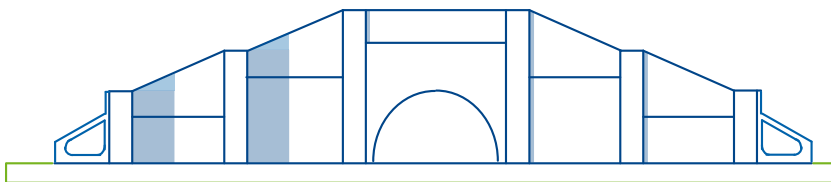
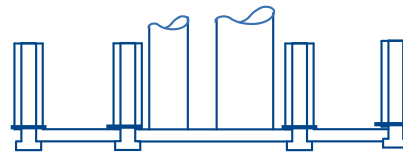
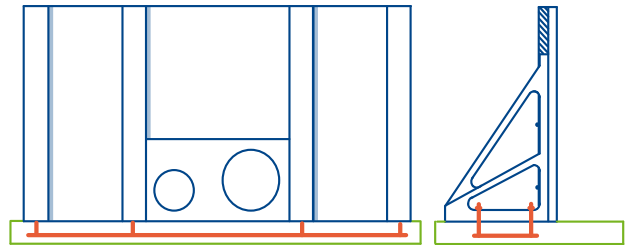

Further examples of the types of Culvert Wingwalls are available on our website [www.althon.co.uk](http://www.althon.co.uk)

Each PCC Culvert Wingwall is designed to suit a specific application and a full design service is available, please contact the Althon Sales office on 01603 488700



[sales@althon.co.uk](mailto:sales@althon.co.uk)

## Althon Headwall H3G

Approximate weight 150kg.

A one-piece glass reinforced cement (GRC) headwall with an opening to suit 150mm diameter pipes and knockout webs to enlarge to 225mm and 300mm diameter pipes.

Stainless steel sockets are provided for the attachment of gratings. The dimensions of the unit are as the H3C PCC unit on page 3 with a reduced toe depth of 150mm and nominal wall thickness of 20mm.

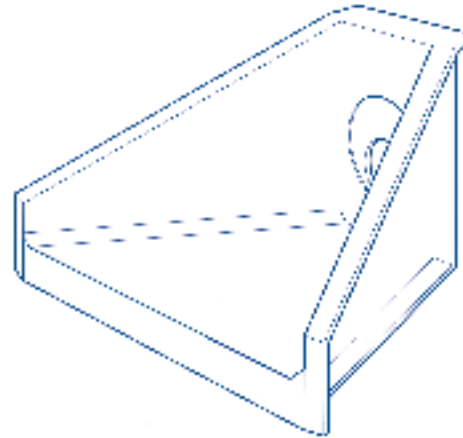

## General Purpose Headwalls

Manufactured in GRC and provided with a unique anchorage system. A lightweight recessed headwall suitable for most situations where batter angle is not less than 45 degrees and for use in minor water courses with moderate flows.

### Althon Small General Purpose Headwall GPSMALL

A one-piece glass reinforced headwall with an opening to suit 80mm diameter pipes and knockout webs to enlarge to 100mm and 150mm diameter pipes.

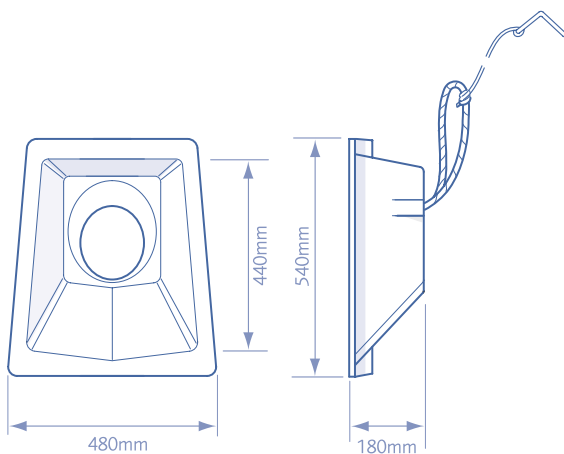

### Althon Large General Purpose Headwall GPLARGE

A one-piece glass reinforced headwall with an opening to suit 150mm diameter pipes and knockout webs to enlarge to 225mm and 300mm diameter pipes.

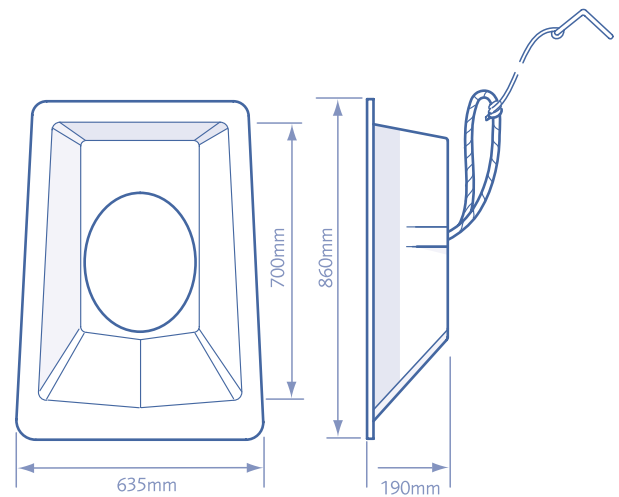

# HEADWALL

[www.althon.co.uk](http://www.althon.co.uk)  
01603 488700

## One Piece Heavy Duty Silt Trap Inlet

To suit Plastic and Clayware pipes up to 600mm I.D. and PCC pipes up to 525mm I.D.

A one-piece reinforced concrete unit with hinged grating and generous silt capacity. Lifting points are cast in to each wall for safe handling using Althon Lifting Clutches.

Heavy Duty Silt Trap	Max Pipe Opening (I.D.) Plastic/Clayware	Max Pipe Opening (I.D.) Concrete	A	B	C	D	Approx Weight kg
1PHDST A	600	525	1065	915	min 400*	1425	1250
1PHDST B	600	525	1065	915	min 400*	1730	1450

\* Can be increased in 150mm increments to a maximum of 850mm

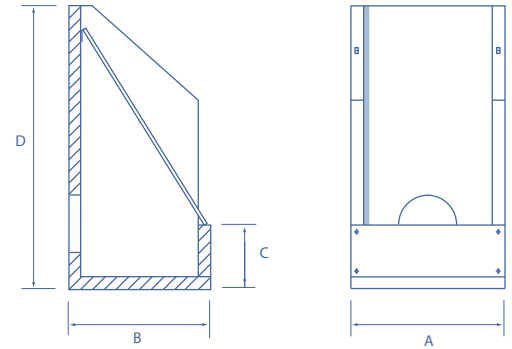

## Two Piece Heavy Duty Silt Trap Inlet

To suit Plastic, Clayware and PCC pipes up to 1200mm I.D.

Sturdy reinforced concrete structures for use on large diameter pipes and ideally suited for use in water courses with high velocities of water flow. Heavy duty galvanised steel weed screen with a removable centre panel for access to the silt chamber is provided. Delivered complete with grating and all necessary fixings. Lifting points are cast in to each wall for safe handling using Althon Lifting Clutches.

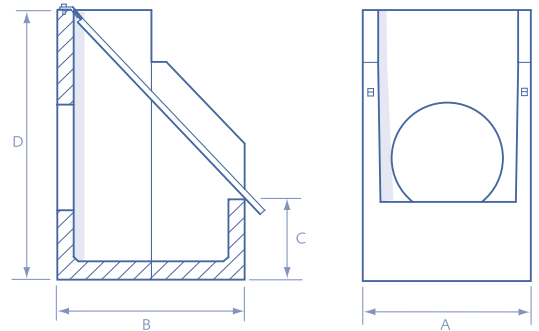

Heavy Duty Silt Trap	Max Pipe Opening (I.D.) Plastic/Clayware	Max Pipe Opening (I.D.) Concrete	A	B	C	D	Approx Weight kg
2PHDST A	750	675	1065	1220	400	1730	1360
2PHDST B	900	750	1370	1220	400	1730	1615
2PHDST C	1050	900	1675	1220	400	1730	1875
2PHDST D	750	675	1065	1220	400	2035	1500
2PHDST E	900	750	1370	1220	400	2035	1785
2PHDST F	1050	1050	1675	1220	400	2035	2070
2PHDST G	750	675	1065	1220	400	2340	1660
2PHDST H	900	750	1370	1220	400	2340	1955
2PHDST I	1200	1200	1675	1220	400	2340	2260



sales@althon.co.uk

## Installation Instructions

### General Purpose Headwalls

1. Dig out sufficiently to allow the headwall flanges to finish flush with the batter.
2. Take the outfall pipe (minimum length 1.5m rigid impervious pipe) and slide it through the headwall so that it protrudes approximately 50mm.
3. Make a good connection with the land drain and seal by returning approximately 150mm of soil into the trench and consolidating.
4. Unravel the string and draw the anchor back along the trench as the rest of the backfilling is completed.
5. Mass concrete should be used to backfill in front and under the toe and well compacted impervious clay around the rest of the unit.
6. Position pipe in prepared trench and insert through backwall of headwall (flush if with flap valve or grating - 50mm protrusion if not).
7. Fill void around pipe with a good quality sand cement mortar.
8. Once satisfied with the positioning of the pipe, backfill in accordance with Engineers instructions.

### Headwalls

Due to the wide variety of site conditions it is inappropriate to give specific information on depths of dig under the structure that is required to support the headwall. Because the ground pressure is low (typically 6.5kn/m<sup>2</sup>) we suggest a sub base of 100mm dry mix concrete just to give a level foundation to sit the headwall onto.

1. Dig out the bank of the watercourse to take the appropriate size of the headwall making sure that the headwall will not protrude into the path of the water flow.
2. Dig out sufficient size trench to take the toe along the front of foundation. If an extended toe is required then increase the depth of the dig to achieve required depth.  
*Note: If an extended toe is required place the headwall on a sufficiently high platform to screw in M12 stainless steel studding into sockets on underside of toe before placement.*
3. Lay a 100mm thick bed of semi dry concrete as a foundation to sit the headwall level or with a slight fall (1:50) from pipe to spill mouth.
4. Using appropriate lifting clutches (available from Althon Ltd) in the anchor positions on the wing walls (with long chains or on H10C Headwalls a spreader bar to prevent excessive side loading) lift the unit and carefully manoeuvre into position on prepared foundation. (For the H20C and H28C separate instructions are available on request or can be viewed on our website.)

### Angled Headwalls

Angled Headwalls are supplied with a separate toe and therefore the order of installation differs slightly from above.

The toe should be installed first; mass concrete should be used to backfill in front and under the unit. Lay a 100mm thick bed of semi-dry concrete as a foundation to sit the headwall level or with a slight fall (1:50) from pipe to spill mouth. This will allow for the headwall then to be lowered over the M16 studs of the separate toe piece and onto the pre-prepared foundation.

### Silt Traps

1. Heavy Duty Silt Traps should be installed on a level base, if necessary bed on 100mm of dry mixed concrete.
2. Two piece units should be lifted into position separately.
3. Ensure that the drain pipe is flush or slightly protruding through the backwall.
4. On the two piece units use the four bolts through the brackets at each side to keep the units together for backfilling, do not over-tighten.
5. Fill void around pipe with a good quality sand cement mortar.
6. Clean out loose materials from the floor before fitting the grating and its retaining brackets.
7. Carefully complete the backfilling and consolidate to the original profile.

# HEADWALL

[www.althon.co.uk](http://www.althon.co.uk)

01603 488700

## SUPPLY

### Ordering

Please contact our Sales Office at Norwich.

### Prices and Conditions of Sale

Information on request from our Norwich office.

### Delivery

Information on request from our Norwich office.

## TECHNICAL SERVICES

To support architects, engineers and contractors in designing and installing the Headwall System, our Design Services Department offers computer aided scheme design, hydraulic performance calculations and advice on installation.

### Contact Information

Our telephone hotline: **01603 488700**

Fax line: **01603 488598** or

E-mail address: **sales@althon.co.uk**

The information contained in this publication is believed to be correct at the date of publication, but it should be understood that between publications there may be changes in pertinent standards or regulations affecting the accuracy of the information contained therein.

## Also from Althon



Althon SUDS  
The SEL Source Control System

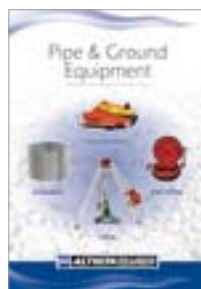

Althon Pipe and  
Ground Equipment



Althon High Capacity  
Channel Drainage System



Virtual Curtain  
Gas Migration Solutions

Please contact



**ALTHON LIMITED**, Vulcan Road South, Norwich NR6 6AF

Telephone: 01603 488700 Fax: 01603 488598 Email: sales@althon.co.uk

[www.althon.co.uk](http://www.althon.co.uk)